

DESCRIPTION

- Metal construction with CH, BN&ORB finish

STANDARD

- Comply with QB/T 1560-2006
- Chrome plated finish passed AASS 24H grade 10, BN&ORB finish passed ES160 and AASS 24H grade 10.

WARRANTY

- 5 years limited warranty except artificial damage and chemicals erosion

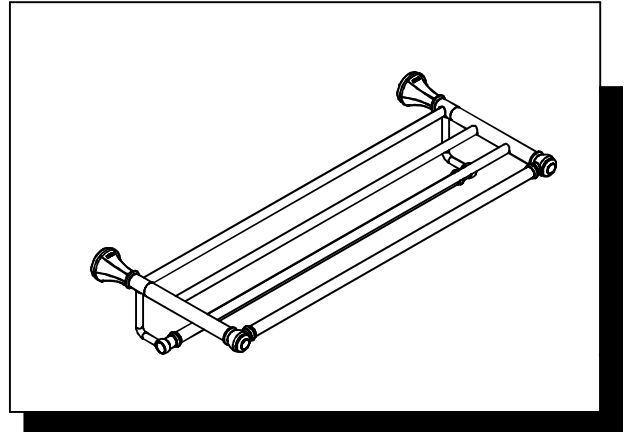

NOTE: ALL DIMENSIONS ARE MM.

DOUBLE TOWEL SHELF
Models: ACC2201 Series

