

DESCRIPTION

- Metal construction with chrome plated and BN finish

STANDARD

- Comply with QB/T1560
- Chrome plated and BN finish pass AASS 24H grade 10.

WARRANTY

- 5 years limited warranty except artificial damage and chemicals erosion

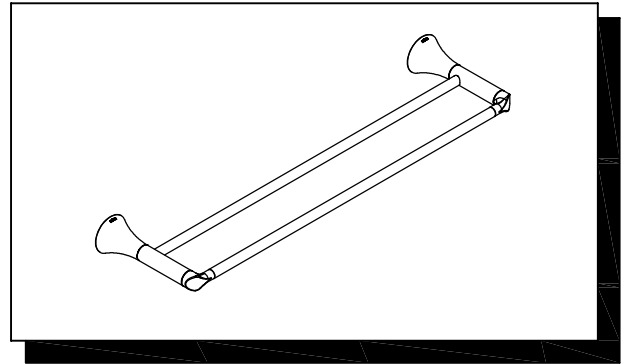

Cynthia Series Accessories: Double Towel Bar (60cm)
Models: ACC1702/ACC1702BN

