

MOEN® 摩恩

双把手面盆龙头

安装说明书

Two-Handle Lavatory Faucet

INSTALLATION INSTRUCTIONS

如需安装支持，配件丢失等，请联系MOEN。
(中国) 400-630-8866
www.moen.cn

PLEASE CONTACT MOEN FIRST
For Installation Help, Missing or Replacement
Parts
(China) 400-630-8866
www.moen.cn

推荐工具

为了安全和让安装和替换变得容易，Moen建议您使用以下工具：

HELPFUL TOOLS

For safety and ease of replacement, Moen recommends the use of these helpful tools.



护目镜
Safety Glasses

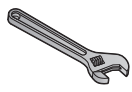

活动扳手
Adjustable Wrench

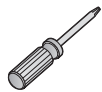

十字螺丝刀
Phillips Screwdriver



钳子
Pliers

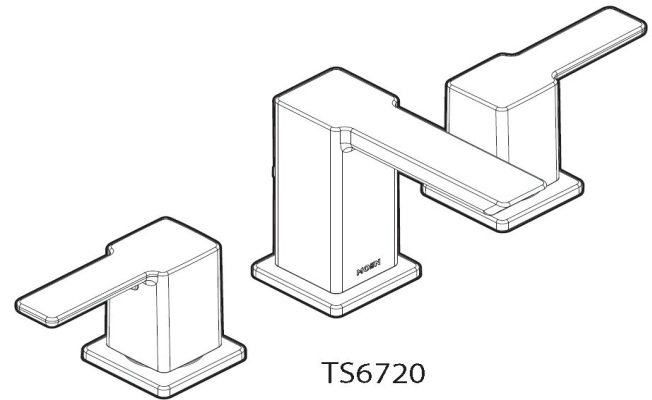

TS6720

图片仅供参考
(款式因型号而异)

Image is for reference only
(Style varies by model)

记录购买的型号：
(保存安装说明书以备将来参考)

Record Purchased Model Number:
(Save instruction sheet for future reference)

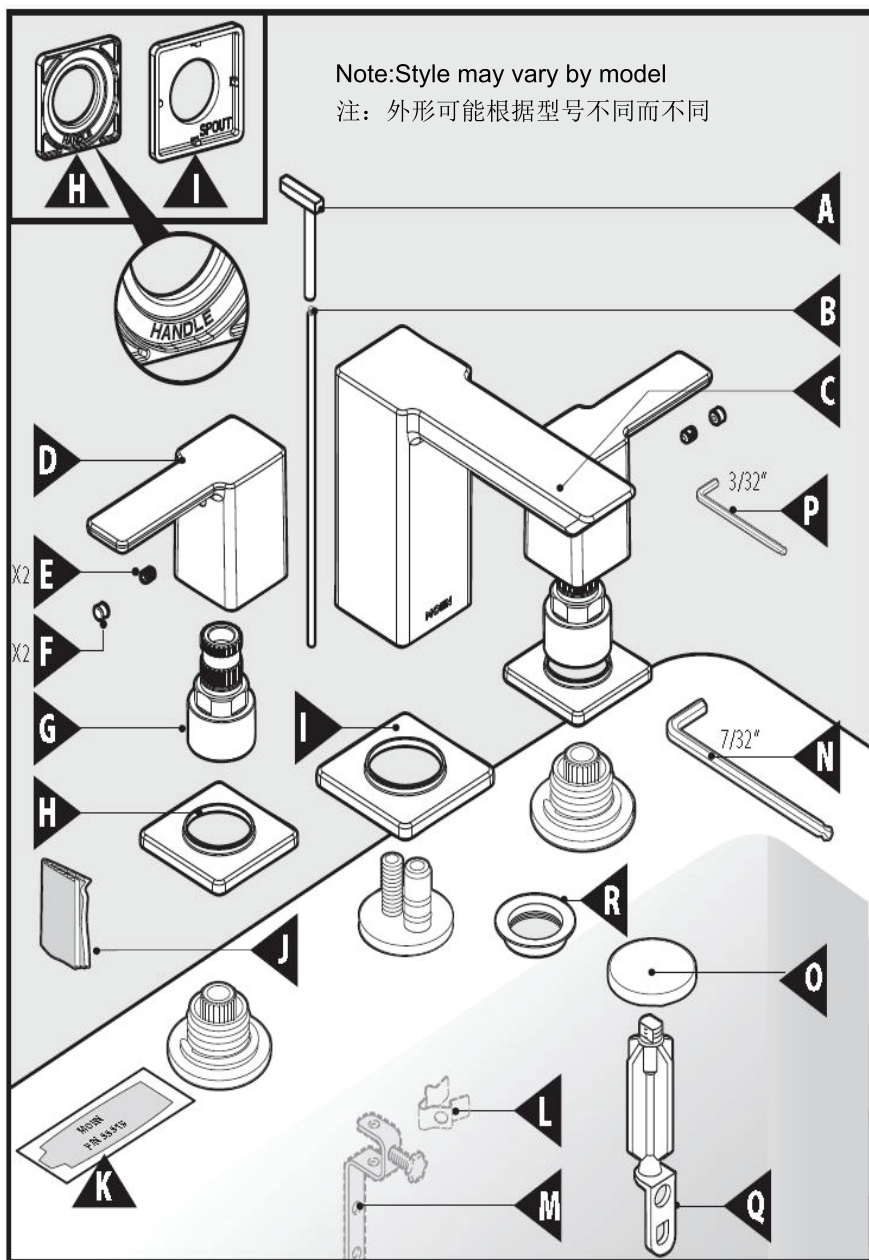

尊敬的顾客:

非常感谢您选用摩恩产品。本产品将在今后许多年中为您提供可靠的服务。每个摩恩产品均采用了高标准的材料和新的生产工艺技术，因而每个摩恩产品都具有极好的耐用性。我们确信在今后许多年中，您都可以享受摩恩产品为您带来的舒适和方便。为了您的安装顺利，请仔细阅读这些指南。

安装和连接:

1. 本产品已经出厂检测及调试，请勿自行拆卸；
2. 请检查在您将要安装龙头的地方没有隐蔽的电缆和管道；
3. 安装前，请务必先清除墙体预埋水管内的杂质及污泥，以免影响出水功能！

敬告：在墙上钻任何孔时，请确保在您准备钻孔的地方没有隐蔽的管道和电缆！
申明：本公司保留更改产品结构不另行通知的权利。

清洗:

清洗本产品时需要小心。尽管本产品的表面镀层极其耐用，但仍有可能被尖利摩擦物或打光物损伤。清洗时只需要用湿布轻轻擦拭，然后用软毛巾拭下即可。

Installation and Connections

1. This product has passed functionality tests prior to leaving the factory. Please do not dismantle by yourself.
2. Please ensure there are no hidden service pipes and cables where you intend to drill.
3. Please ensure pipes are clear of debris to avoid any blockage that could affect quality of water spray.
4. Follow safety precautions while drilling and installing.

We reserve the right to alter the structure of the product without notice.

Cleaning

Cleaning of this product should be done regularly. Although the finish is extremely durable, it can be damaged by harsh abrasives or polish. To clean, simply wipe gently with a damp cloth, and dry with a soft towel.

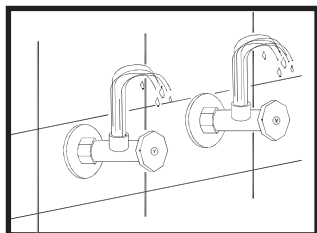

打开冷热供水，排水管内积累的残渣。否则将有损龙头。
Flush hot and cold water supply lines to remove any debris in the supply lines that has accumulated and could damage the faucet.

移除旧龙头注意事项:

拆除现有水龙头或拆卸阀门之前，请务必先关闭供水。打开水龙头手柄以释放水压，确保完全关闭水源。

CAUTION — TIPS FOR REMOVAL OF OLD FAUCET:

Always turn water supply OFF before removing existing faucet or disassembling the valve. Open faucet handle to relieve water pressure and ensure that complete water shut-off has been accomplished.

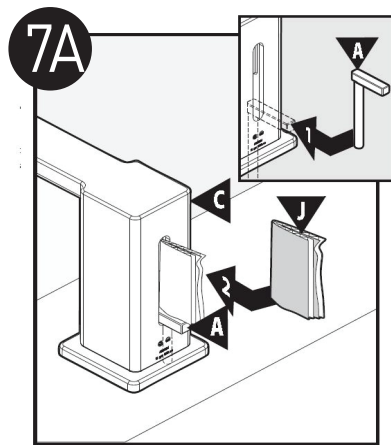
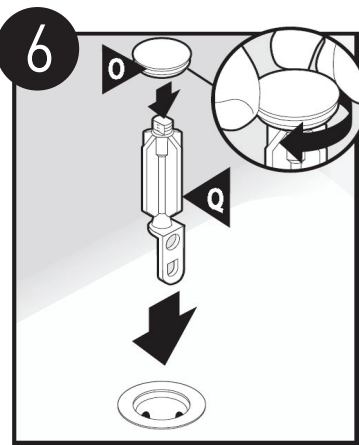
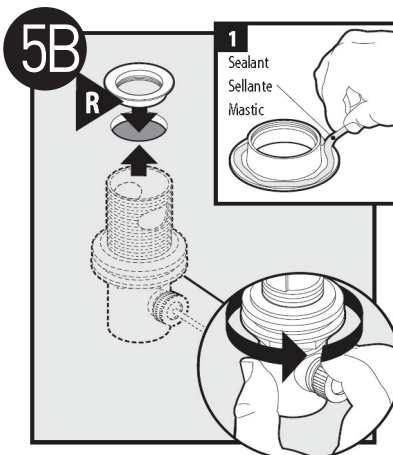
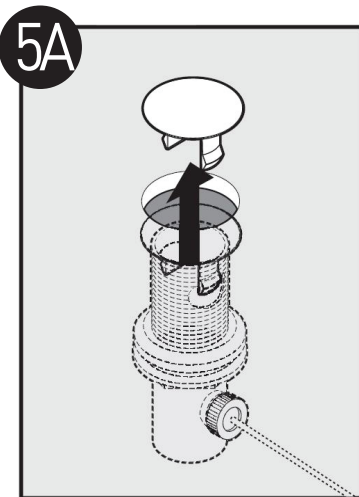
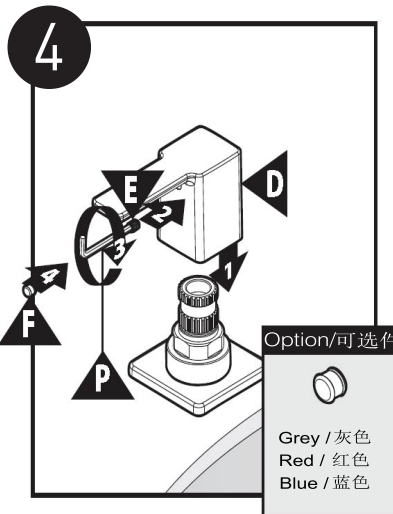
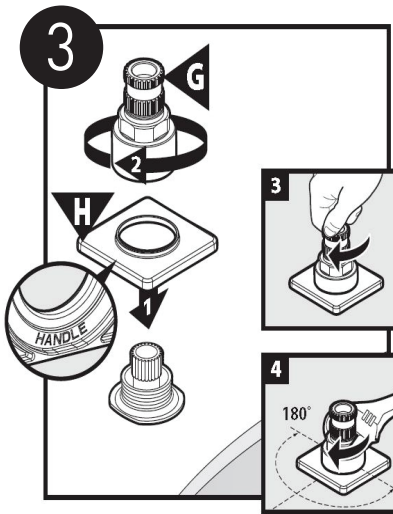
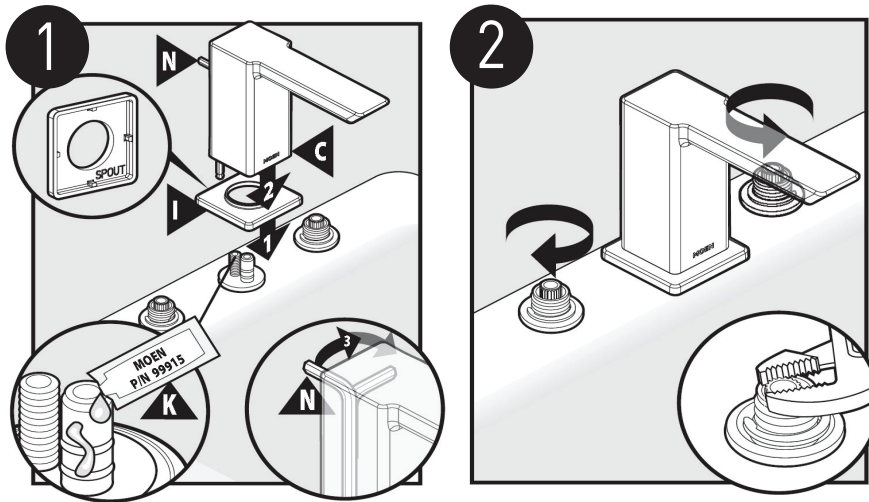

Option/可选件
 Grey / 灰色
 Red / 红色
 Blue / 蓝色

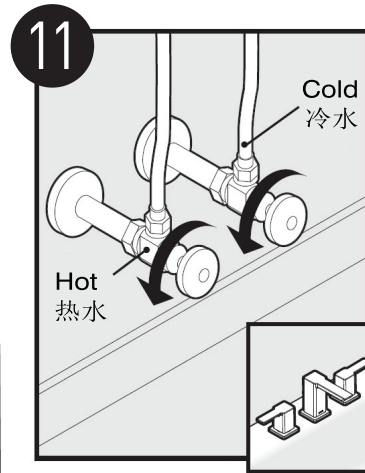
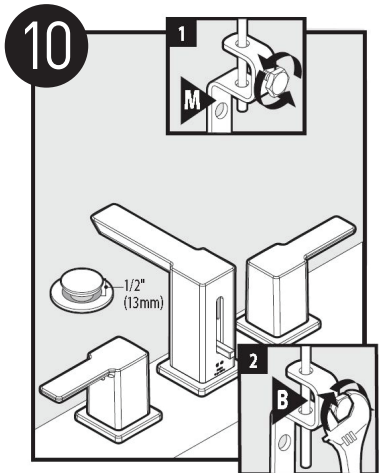
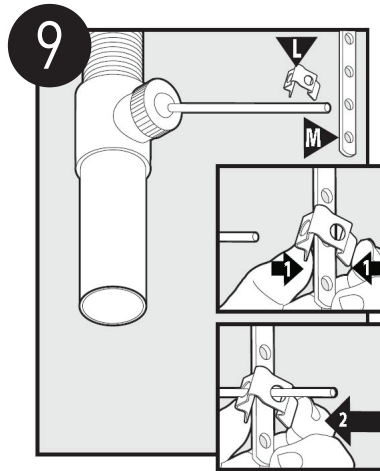
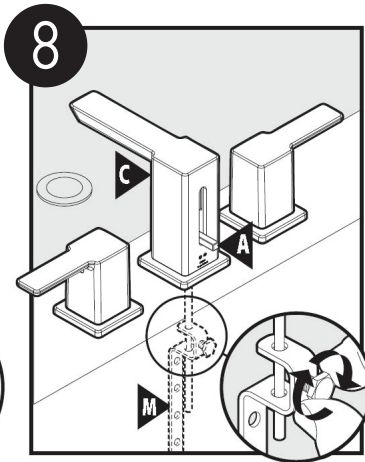
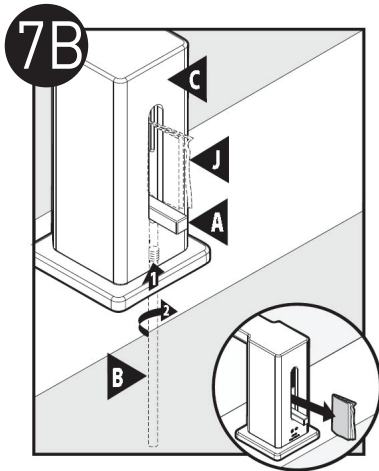

Irregular Flow
 水型出现异常
 按照以下步骤清洗限流器

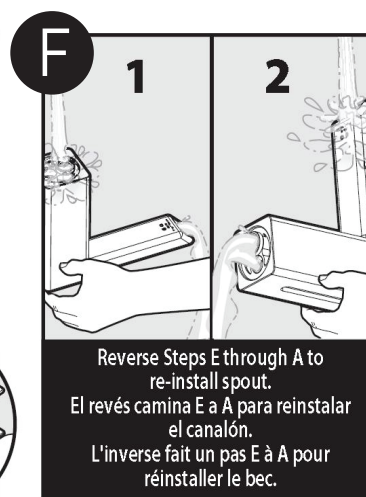
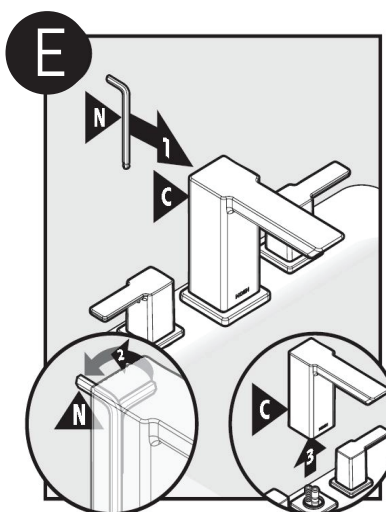
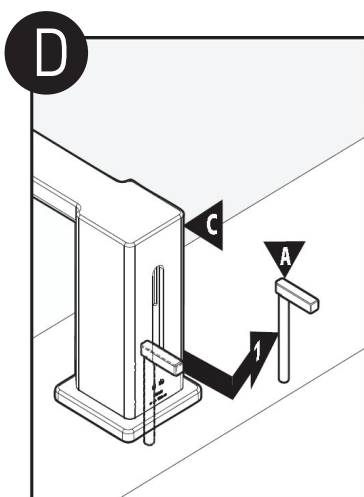
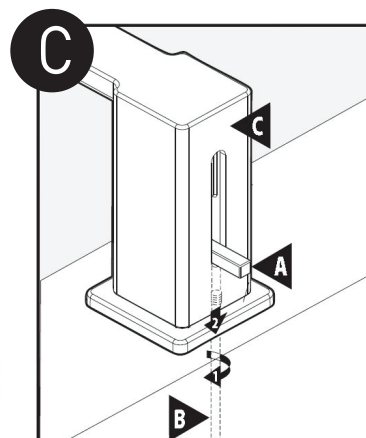
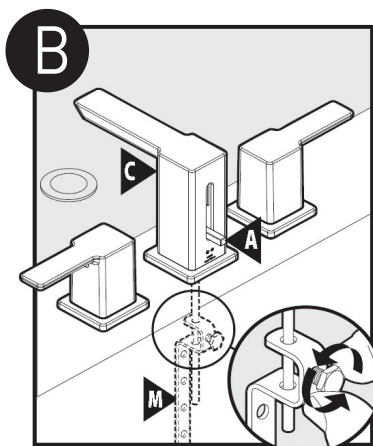
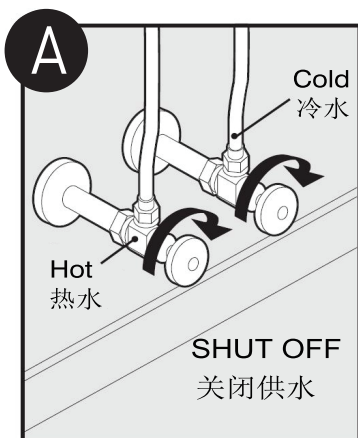

产品售后保修条款

摩恩产品是在高质量标准及生产工艺下制造的，摩恩承诺为消费者购买的洁具产品提供有期限免费保修及终身维修服务。

龙头免费保修期为：阀芯5年，电磁阀感应器2年，其它附件如淋浴杆、软管、花洒、落水、把手、装饰盖、提拉杆、混水器等等的保修期均为1年有限。均自消费者购买日（以摩恩产品分销商开具的发票或收据上载明日期为准）起计。

免费保修范围为产品及产品配件（如淋浴杆、软管、花洒、落水、把手、装饰盖、提拉杆、混水器等）由于材质及工艺原因而造成的故障或损坏。免费保修期内，我们将无偿为您提供修理服务及更换发生故障的产品或产品配件。摩恩的售后服务责任仅限于对故障产品的修理，而不延及您因产品故障而发生的其他损失，法律另有规定的除外。

您需了解：产品外观碰伤、刻划痕迹，以及滥用及不正当保养所导致的故障或损坏，均不属于免费保修范围。即使在免费保修期内，属下列（1）-（5）情况之一的，需酌情收取修理费用：

1. 不能出示相符的保修卡和有效购买凭证情况的，
2. 未按使用说明书告知的使用方法和注意事项造成的故障，
3. 自行拆卸、维修、改装所造成的故障和损坏，
4. 由于不可抗力等外部原因引起的故障和损坏，
5. 由于运输、搬卸、挤压等造成的损坏。

对于保修期外或不在保修范围内的产品，如需维修，摩恩将酌情收取上门费、人工费及材料费。

本保修条款仅对原始消费者和酒店行业的购买者有效，并不适用于本产品工业、商业、贸易和非酒店行业的使用。

如对本保修条款内容有任何疑问，请拨打400 630 8866 咨询热线，或向当地分销商咨询。

MOEN LIMITED WARRANTY

We offer limited warranty and lifetime maintenance for Moen products, which are all manufactured with high standards of workmanship.

The period of warranty shall start from the date of purchase of the product (according to the invoice or receipt issued by Moen distributors) and shall cover a period of the following: the warranty period for cartridge is 5 years, the warranty period for solenoid valve sensor is 2 years, the warranty period of other accessories such as shower bar, hose, shower, drain assembly, handle, cover, lift rod, aerator etc. is 1 year. This warranty is your coverage against material and workmanship malfunction or defects in Moen products or components (such as shower bar, hose, shower, drain assembly, handle, cover, lift rod, aerator etc.). During the warranty period, we offer free maintenance and changing of malfunctioned products or product components. Moen's after sales service liability is limited to the maintenance of faulty items and does not cover your other losses caused by product malfunction, except for otherwise stipulated by law.

Cosmetic damages (scratches, dents, etc.) and malfunction or defects caused by abuse or improper maintenance is not covered by this warranty. Although the warranty period remains valid, in case of the following conditions (1) - (5), the maintenance cost (material cost and labor cost) shall still be charged as the case may be:

1. Corresponding warranty card and valid invoice cannot be presented;
2. Faults were caused by the incompliance with the instructions and precautions provided in the user's manual;
3. Damages and faults were caused by self-actuated dismantling, repair and refit;
4. Faults and damages were caused by external factors such as force majeure;
5. Damages were caused by transportation, unloading and extrusion, etc.

This warranty is valid for the original consumers only (including hotel use), and excludes industrial and commercial use of the product (except for hotel use). This card is only responsible for product maintenance rather than any other liabilities.

In the event that the product requires maintenance but exceeds the warranty period, or that the product is not covered by this warranty, labor cost and material cost shall be charged as the case may be.

Please call 400-630-8866 or contact local dealer for any question.

MOEN® 摩恩

合格证

Compliance Certification

产品名称 双把手面盆龙头
Product Name Two-Handle Lavatory Faucet

检验员
Inspector

生产日期
Date of Production

摩恩（上海）厨卫有限公司
中国（上海）自由贸易实验富特北路399号
邮编：200131

MOEN (SHANG HAI) KITCHEN&BATH CO.,LTD
No. 399 Fute North RD, China (SHANG HAI) Pilot Free Trade
Zone, Shanghai 200131 P.R.China