

家用废弃食物处理器

安装使用说明书

Household Food Waste Disposer

INSTALLATION INSTRUCTIONS

如需安装支持，配件丢失等，请联系MOEN。
(中国) 400-630-8866

www.moen.cn

PLEASE CONTACT MOEN FIRST

For Installation Help, Missing or Replacement
Parts

(China) 400-630-8866

www.moen.cn

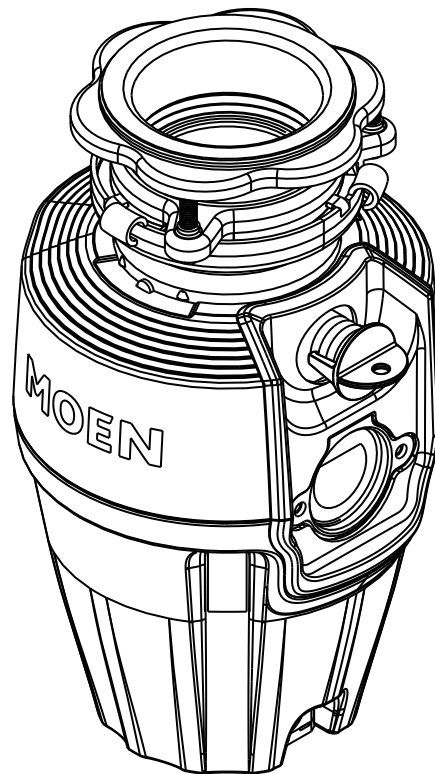

图片仅供参考
(款式因型号而异)

Image is for reference only
(Style varies by model)

推荐工具

为了安全和让安装和替换变得容易，Moen建议您使用以下工具：

HELPFUL TOOLS

For safety and ease of replacement, Moen recommends the use of these helpful tools.



记录购买的型号：
(保存安装说明书以备将来参考)

Record Purchased Model Number:
(Save instruction sheet for future reference)

安装前注意事项

注：本文档内容均与安全有关，请用户必须遵守。本文档中的注意事项解释了危险、危害的程度大小及可能发生的事故，可以帮助你正确地使用本产品。

1. 本废弃食物处理器是家庭范围使用版本，仅可用于家庭性的间歇使用，不能当作商用型的连续使用。
2. 在安装和使用本废弃食物处理器前，请务必阅读本手册，并遵循手册中的建议，以避免操作中可能出现的故障；如果您有任何问题，请与我们分销商联系。
3. 我们为您制造的废弃食物处理器是一台十分可靠的家电产品。该产品独特的设计使您能够轻松自如地清除饭前、饭后厨房中所产生的有机食物垃圾。处理器使用十分简便，您只需打开水龙头，启动处理器，再倒入食物垃圾。处理器就会将食物垃圾研磨成极细小的颗粒并冲入排水管道，不会产生任何问题。
4. 在对本食物垃圾处理器进行任何操作前，请仔细阅读和理解使用说明书。
5. 请务必阅读安全指南，以免发生事故和故障。
6. 如果正在使用的电器产品附近有小孩，请仔细照看以免发生人身意外伤害。
7. 废弃食物处理器工作时，请不要将手指或手放入处理器。
8. 准备清洗或从处理器中取出物体时，请将处理器的电源插头拔出或关闭电源开关。
9. 请用长柄的木勺或木棒来疏通堵塞的处理器。在取出处理器内部的物体时，请使用长柄夹子或钳子。

Precaution before Installation

Note: The users shall comply with all safety instructions in this document. The precautions in this document explain the danger, the degree of harm, and possible accidents, which can help you to use this product correctly.

1. This waste food disposer is a family-wide version, which can only be used for intermittent household use, and cannot be used as a commercial continuous use.
2. Before installing and using this food waste disposer, please be sure to read this manual and follow the recommendations in the manual to avoid possible malfunctions during operation. If you have any questions, please contact our distributor.
3. The food waste processor we made for you is a very reliable home appliance. The product is unique design that allows you to easily remove the organic food waste generated in the kitchen before and after meals. It is very easy to use, you only need to turn on the faucet, start the processor, and then pour in the food waste. The processor will Grind food waste into very fine particles and flushing them into the drainage pipe to avoid clogging.
4. Please read and understand the instruction manual carefully before performing any operation on this food waste disposer.
5. Be sure to read the safety guide to avoid accidents and malfunctions.
6. Do not leave children unattended by electrical appliances such as the waste disposer.
7. When the food waste disposer is in use, please do not put your fingers or hands in the disposer.
8. When preparing to clean or remove objects from the processor, unplug the processor or turn off the power switch.
9. Please use a long-handled wooden spoon or stick to clear the clogged processor. When removing objects inside the processor, use long-handled clamps or pliers.

10. 为了减少特殊物品对处理器造成不必要的伤害，请不要将下列物品倒入处理器。

- 贝壳类，如蛤壳、牡蛎壳、生蚝壳等
- 鱼鳞
- 管道清洁用品
- 玻璃、瓷器或塑料、编织袋、塑料袋
- 整根的大骨头
- 金属，如瓶杯、听罐或铝箔
- 整根的玉米棒子
- 粗纤维的蔬菜、水果，如老芹菜、莴笋皮、菠萝头子
- 具有较强韧性与拉伸性的垃圾，如橡胶瓶塞、生肉皮
- 本产品适用于除上述物品以外的食物垃圾，生活垃圾严禁放入

11. 在不使用处理器时，请将水槽落水孔塞子盖好，以免处理器内掉入其它物体。

12. 请在装好防溅橡胶圈后再使用处理器。

13. 请详细阅读本手册的接线部分，以保证处理器良好接地。

14. 如果您不熟悉电器知识，请查阅电工手册或向有资格的电工咨询。

15. 该产品底部，电源线引出端的正背面装有过载保护器，在安装时务必保证保护器复位按钮能够被易于触及。

10. To reduce damage to the processor caused by special items, please do not pour the following items into the processor.

- Shellfish, such as clam shells, etc.
- Fish scales
- Pipe cleaning supplies
- Glass, porcelain or plastic, woven bag, plastic bags
- Whole large bones
- Metal, such as bottle caps, tin can or aluminum foil
- Whole corn on the cob
- Crude fiber vegetables and fruits, such as old celery, lettuce skin, pineapple head
- Trash with strong toughness and stretchability, such as rubber bottle stoppers, raw meat skins
- This product is suitable for food waste other than the above items, and household waste is strictly prohibited

11. When the processor is not in use, please cover the sink plug to prevent other objects from falling into the processor

12. Please install the splash-proof rubber ring before using the processor.

13. Please read the wiring part of this manual carefully to ensure that the processor is well grounded.

14. If you are not familiar with electrical appliances, please refer to the electrician's manual or consult a qualified electrician.

15. At the bottom of the product, there is an overload protector on the front and back of the lead-out end of the power cord. When installing, make sure that the reset button of the protector is easily accessible.

产品描述 Product Description

产品信息 Product Information

现有产品的结构尺寸 (单位: 厘米 cm) The structure size of the existing product (unit:cm)

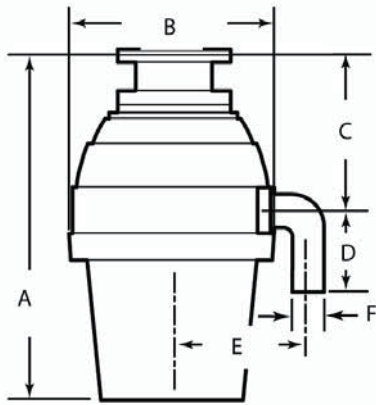

型号 MODEL	MEX50MCL	MEX75MCL
功率 POWER	475W	520W
尺寸 Dimension (cm)	A	34.0
	B	19.0
	C	17.5
	D	7.0
	E	13.5
	F	4.8

管路搭配 Pipeline Matching

• 垃圾处理器搭配双槽 Waste Disposer with Double Slot

下水管径 Drain Connection Size	搭配摩恩双槽 With Moen Double Solt	其它品牌 (单) 水槽 (如管不匹配) With Others brands Single Solt (if the pipe not match)
40 管 G1 ½ (D40)	PJW1009	SB021+PJW1009
50 管 G2 (D50)	PJW1018+PJW1014	SB032+PJW1018+PJW1014

• 垃圾处理器搭配单槽 Waste Disposer with Single Slot

下水管径 Drain Connection Size	搭配摩恩单槽 With Moen Single Solt	其它品牌 (单) 水槽 (如管不匹配) With Others brands Single Solt (if the pipe not match)
40 管 G1 ½ (D40)	PJW1013	SB012R+PJW1013
50 管 G2 (D50)	PJW1018+PJW1013	SB033+PJW1018+PJW1013

落水口标配112mm口径, 如水槽落水口偏大, 则需选购140mm 变径器PJW1010.

The sinkhole comes standard with 112mm caliber. If the sinkhole is too large, you need to purchase a 140mm reducer PJW1010.

装箱清单 Packing List

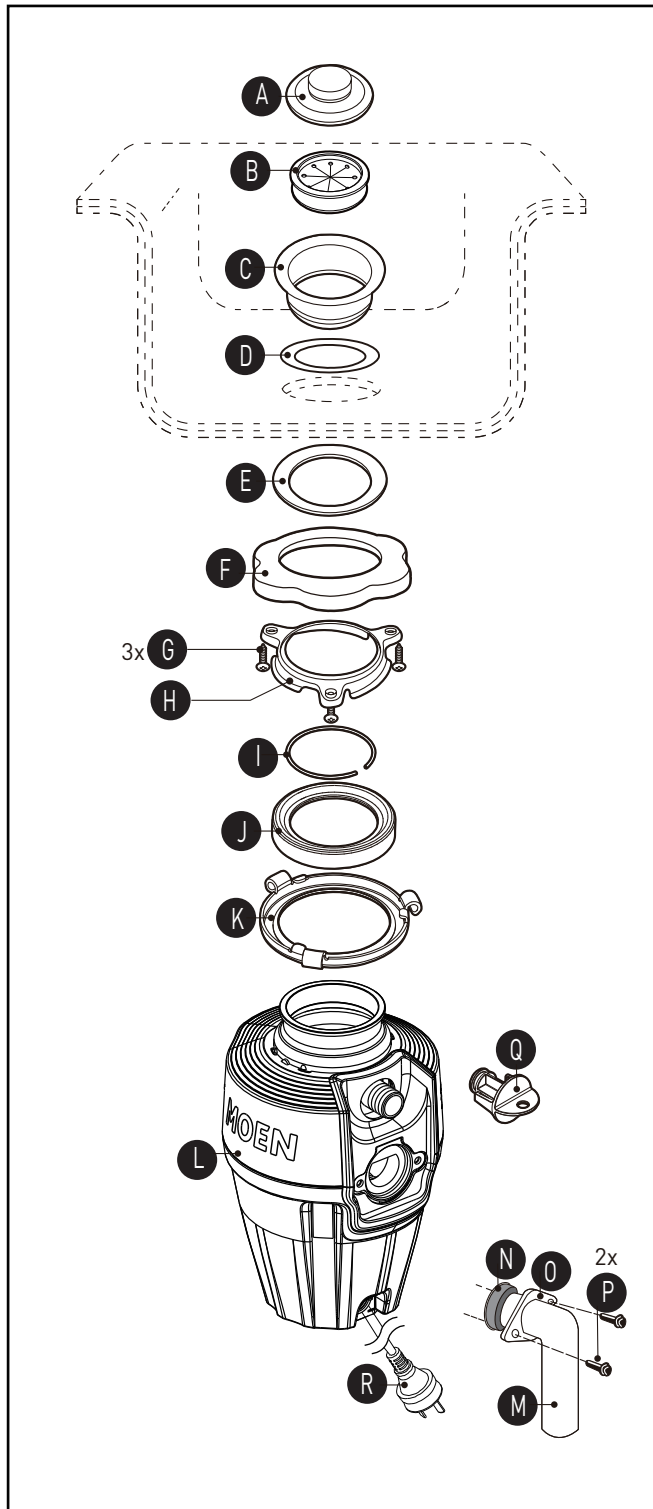

零件清单

- A. 盖子
- B. 防溅橡胶件
- C. 不锈钢法兰
- D. 法兰橡胶平垫
- E. 腊圈
- F. 支撑环
- G. 螺丝(3x)
- H. 装配环
- I. 卡箍
- J. 橡胶件
- K. 连接环
- L. 处理器
- M. 弯管
- N. 弯管橡胶件
- O. 法兰盘
- P. 法兰盘螺丝(2x)
- Q. 洗碗机塞子
- R. 电源线

Parts list

- A. Lid
- B. Splash-proof rubber parts
- C. Stainless steel flange
- D. Flange rubber flat gasket
- E. Wax ring
- F. Support ring
- G. Screw (3x)
- H. Mounting ring
- I. Clamp
- J. Rubber parts
- K. Connecting ring
- L. Processor
- M. Elbow
- N. Elbow rubber parts
- O. Flange
- P. Flange screw (2x)
- Q. Dishwasher plug
- R. Power cord

安装步骤 Installation Steps

注意：处理器已在出厂前组装好，因此请您在安装前仔细观察各部件及固定装置的安装步骤。同时，请按下述方法安装。

Note: The processor has been assembled before leaving the factory, so please carefully observe the installation steps of each component and fixing device before installation, please install as follows.

1. 安装法兰组件

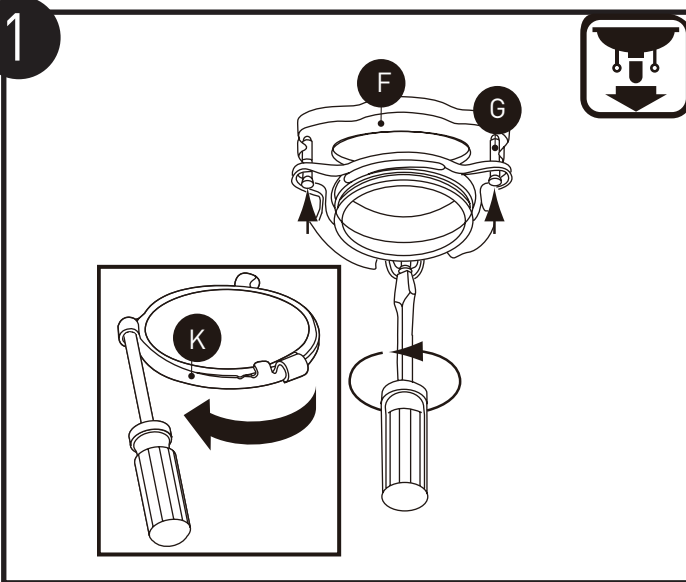

用起子将法兰组件上的螺丝 (G) 拆松，再用起子插入连接环 (K)，顺时针作用力，将处理器从法兰组件上拆下。

Use a screwdriver to loosen the screw (G) on the flange assembly, then insert the screwdriver into the connecting ring (K), and apply force clockwise to remove the processor from the flange assembly.

Install the Flange Assembly

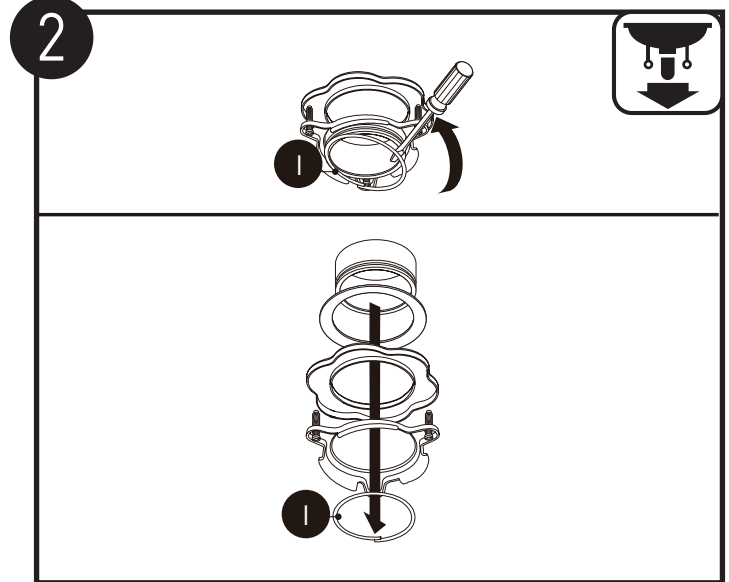

用起子将法兰组件的卡箍 (I) 拆下，将其他零件从法兰组件上按图示顺序拆开。

Use a screwdriver to remove the clamp (I) of the flange assembly, and remove the other parts from the flange assembly in the order shown in the figure.

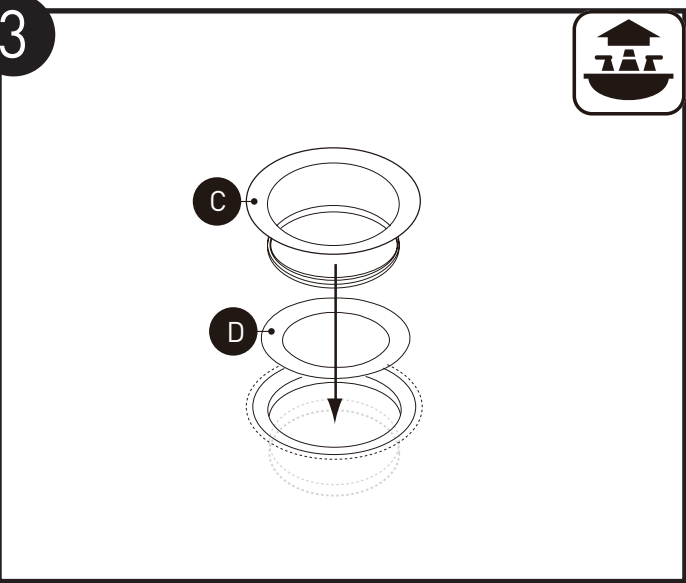

将法兰 (C) 下槽口穿过法兰橡胶平垫 (D)，再将法兰 (C) 穿过水槽孔装入 (法兰橡胶平垫 (D) 处于法兰 (C) 与水槽间，起密封防水作用)。

Pass the lower slot of the flange (C) through the flange rubber flat gasket (D), and insert the flange (C) through the groove hole (the flange rubber gasket (D) is in the flange (C) and the groove, play a role of sealing and waterproofing).

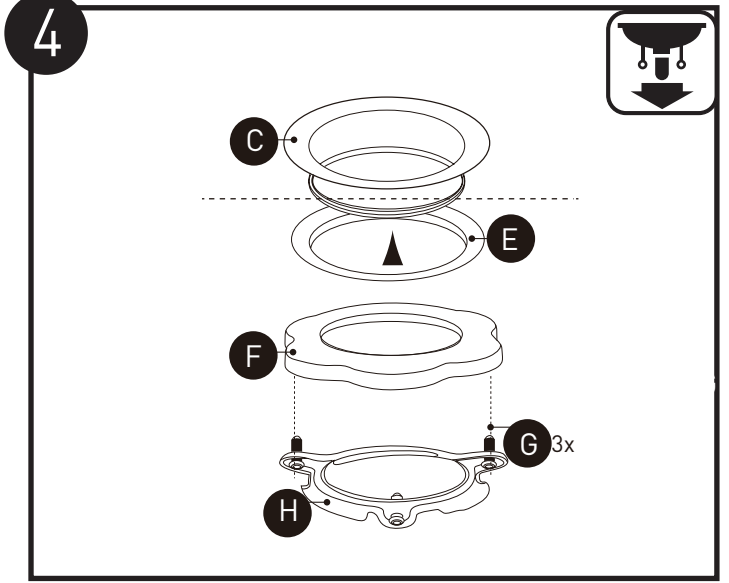

在水槽下面，按顺序蜡圈 (E)，支撑环 (F)，装配环 (H) 装入穿过水槽的法兰 (C) 上，用螺丝 (G) 固定。注意：此时螺丝 (G) 不需要装紧。

Under the water tank, install the wax ring (E), support ring (F), and assembling ring (H) onto the flange (C) bottom. Fasten with screws (G). Note: The screws (G) do not need to be tightened at this time.

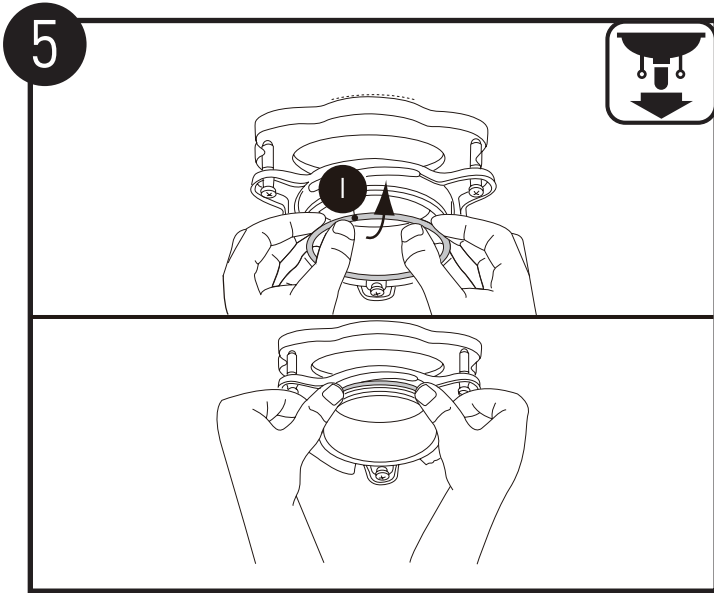

将卡箍(I)装入法兰(C)的卡槽内。
Install the clamp (I) into the groove of the flange (C).

2. 连接电源线

安装使用废弃食物处理器，需要您在厨房改造中预留电源插座及开关。

提示：插座电路中要求有良好接地，必须有漏电保护装置！在安装前，请不要将电源连接到处理器上，请将电源关闭或拿掉保险丝。

如果电源软线损坏，为了避免危险，必须由制造商、其维修部或类似部门的专业人员更换。

请注意：本废弃食物处理器的使用电压已标明在处理器底部盖板上。同时底盖铭牌 标签上还标明了其它相关信息。

A. 本处理器仅使用交流电。

B. 处理器电源连接采用插头的连接方式。为了安全和操作方便建议给处理器。

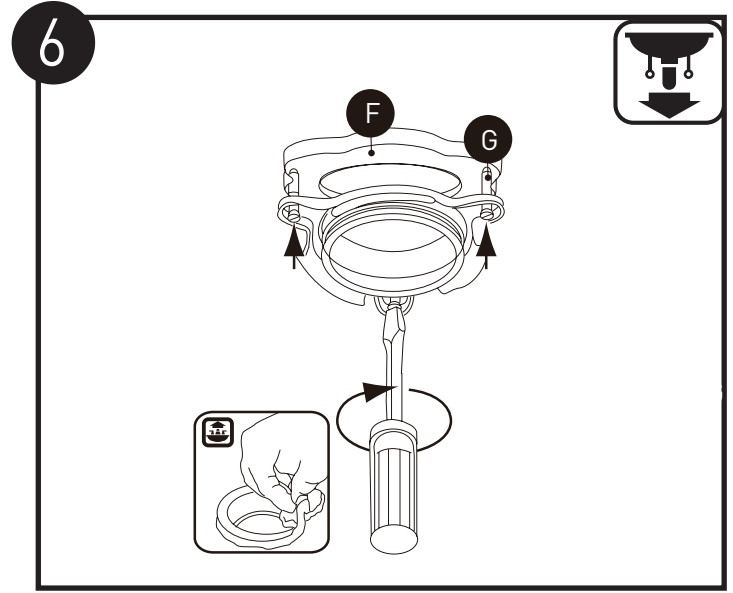

用起子将螺丝(G)锁紧。
Tighten the screw (G) with a screwdriver

Connect the Power Cord

To install and use waste food processors, you need to reserve power sockets and switches in the kitchen renovation.

Tip: A good grounding is required in the socket circuit, and there must be a leakage protection device! Before installation, please do not connect the power supply to the processor, turn off the power supply or remove the fuse.

If the power cord is damaged, in order to avoid danger, it must be replaced by professionals from the manufacturer, its maintenance department or similar departments.

Please note: The operating voltage of this waste food disposer has been marked on the bottom cover of the disposer, other relevant information is also present on the nameplate label on the bottom cover.

A. This processor only uses AC power.

B. The processor power connection adopts the plug connection method. This is recommended to the processor for safety and ease of operation.

3. 连接洗碗机 (可选) Connect the Dishwasher (Optional)

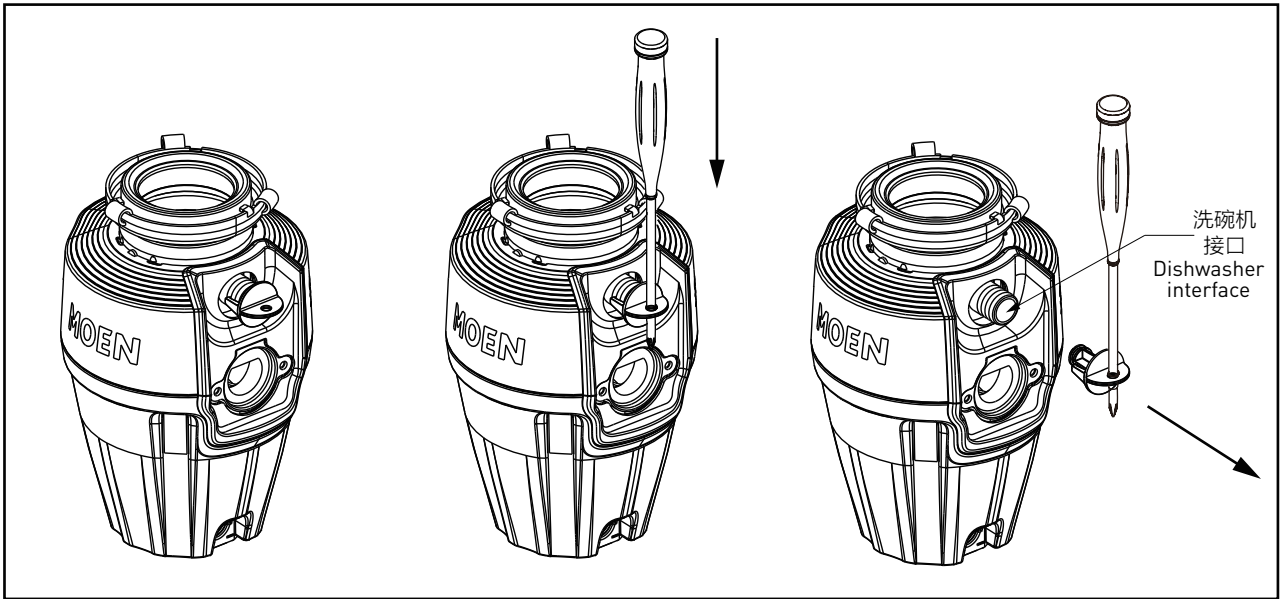

如果您使用洗碗机，请按上图指示进行连接。如果不连接洗碗机则继续下一步安装。用一个起子插入到洗碗机塞子圆孔中，按图示方向拉出塞子，只需将洗碗机的软管同处理器的洗碗机接口相连接即可（见上图）。

If you use a dishwasher, please follow the instructions above to connect. If the dishwasher is not connected, proceed to the next step of installation. Insert screwdriver into the hole of the dishwasher stopper, pull out the stopper in the direction shown, and just Connect the dishwasher hose to the dishwasher port of the processor (see Figure above).

4. 固定排水弯管 Fix Drainage Elbow

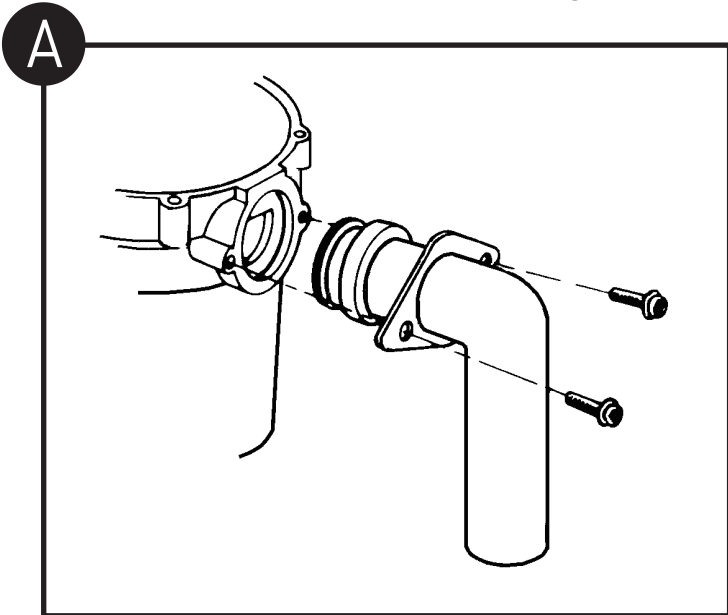

将排水弯管接到处理器上（见图 A）拧紧螺丝。

Connect the drain elbow to the processor (see Figure A) and tighten the screws.

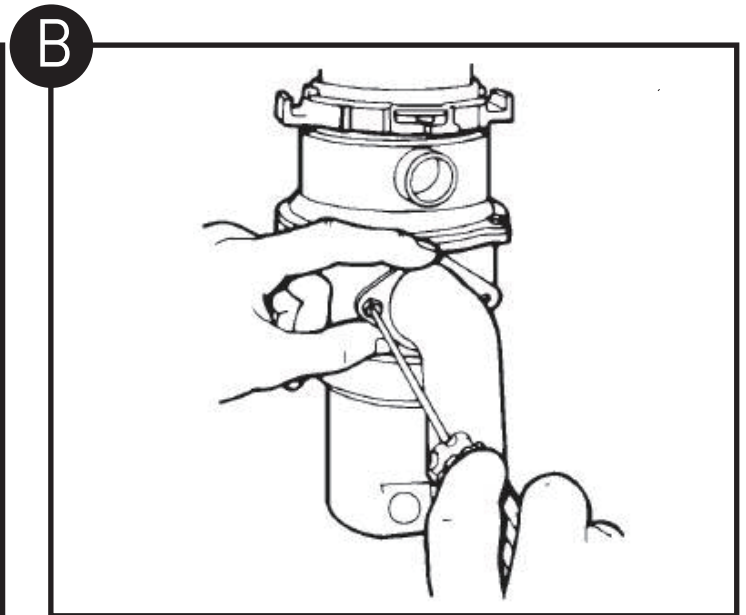

确认所有的管件已接连牢固。（见图B）

Confirm that all the pipe fittings been connected firmly.(see FigureB)

5. 安装垃圾处理器主体 Install the Main Body of the Garbage Disposer

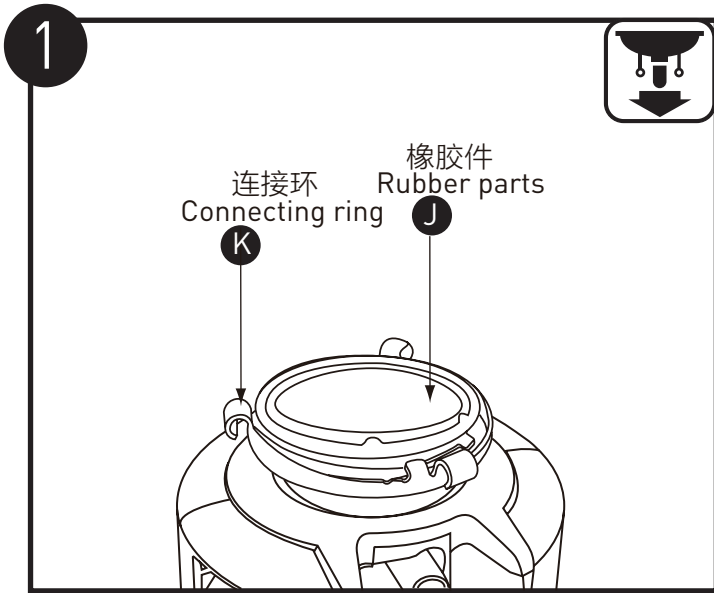

将连接环 (K) 装入处理器 (L) 的贮水槽上, 弧形开口朝下, 再将橡胶件 (J) 装在处理器 (J) 的贮水槽上, 有凹槽的朝下。

Put the connecting ring (K) onto the processor water tank (L) with the shaped opening facing down, and install the rubber piece (J) on the water tank (J) with the groove facing down.

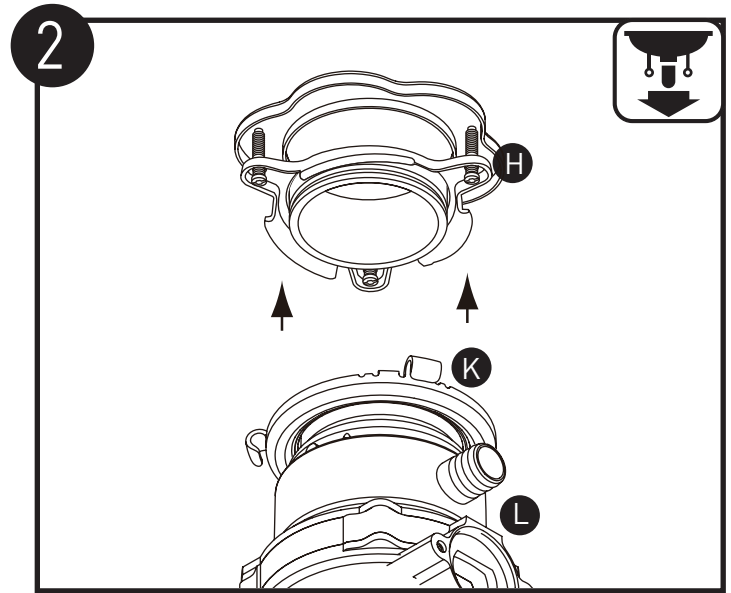

把处理器 (L) 与法兰组件连接, 此时需要将装配环 (H) 卡进连接环 (K) 的卡槽中。

Connect the processor (L) to the flange assembly. snap the mounting ring (H) into the slot of the connecting ring (K).

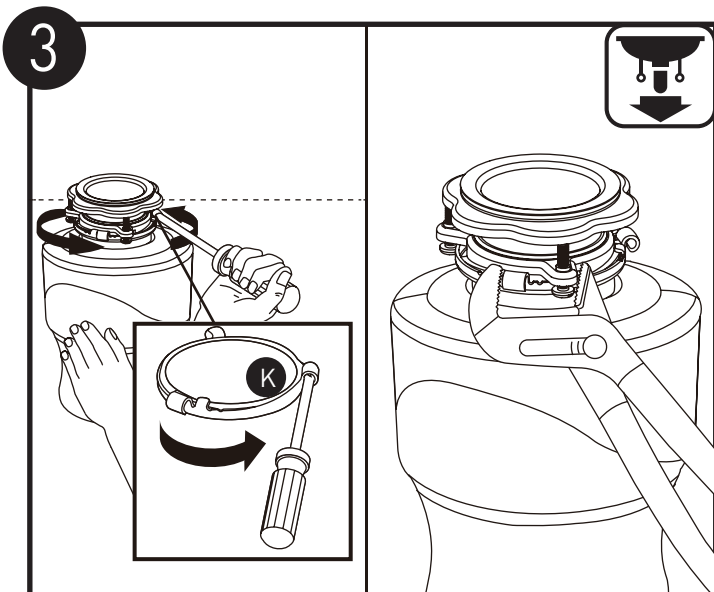

用起子套进连接环 (K) 的弧形开口处, 逆时针作用, 处理器 (L) 与法兰组件旋紧。再用夹钳按图示要求操作, 将其再锁紧, 使之连接更可靠。

Slide a screwdriver into the arc opening of the connecting ring (K) and turn counter-clockwise to tighten the processor (L) and the flange assembly. Use the clamp to operate as shown in the figure, and re-lock it to make the connection more reliable.

6. 无线移动插座的安装

垃圾处理器无线移动插座，安装方便，适用于功率1马力范围的电气装置

- 无需电墙开关
- 方便首次安装
- 电压的适用范围：220-240V

无线移动插座安装：

将无线移动插座插入橱柜内的墙面插座内，再将已装好的处理器的电源插头插入无线移动插座的插孔内。无线开关配有强力双面胶，选择合适的位置安装好（下图）。安装完成，按下无线开关按钮，处理器启动；再按下无线开关按钮，处理器关闭。插座按键也具有开关功能，按压按键可控制电源的通断。

注意：

- 无线开关内部设有自发电装置，无需外接电源或安装电池。
- 无线开关使用强力双面胶固定，请选择好合适的位置再安装。
- 无线开关请安装在无线移动插座6米范围内的墙壁或橱柜垂直面上（见下图），避开油烟区域。
- 如遇积水，请马上停止使用，可使用电吹风完全吹干后再使用。
- 无线开关可能被儿童当作玩具，请安装在儿童够不着的位置。
- 全不锈钢台面因为会出现信号衰减而导致机器无法正常接受信号的现象，所以，建议使用全不锈钢台面的客户，将开关尽可能的置于接近接收装置附近，如果还是无法有效的控制，则建议客户改用空气开关安装

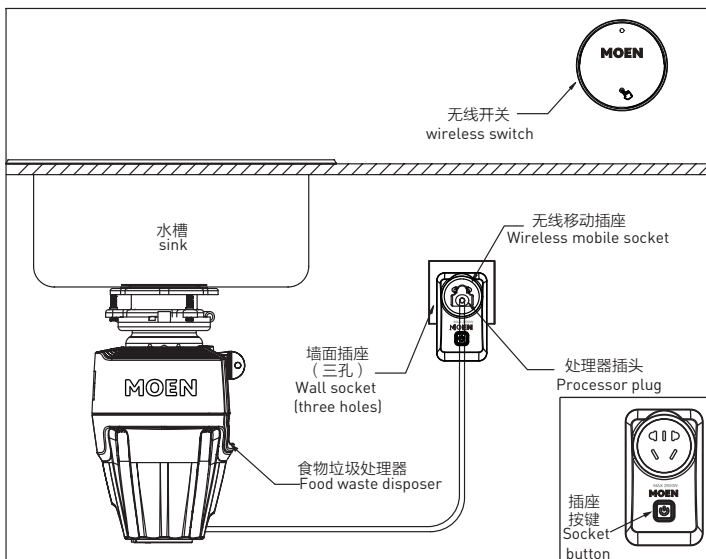

Install the Wireless Mobile Socket

Garbage disposer wireless mobile socket is easy to install and suitable for electrical devices in the power range of 1 horsepower

- No wall switch required
- Easy to install for the first time
- Applicable voltage range: 220-240V

Wireless mobile socket installation:

Insert the wireless mobile socket into the wall socket in the cabinet, Insert the power plug of the installed processor into the socket of the wireless mobile socket. The wireless switch is equipped with strong double-sided tape, Choose a suitable location and install it (The following figure). After the installation is complete, press the wireless switch button to start the processor; press the wireless switch button to start the processor. and press the wireless switch button again to shut down the processor. The socket button also has a switch function and pressing the button controls the power supply on/off.

Note:

- There is a self-generating device inside the wireless switch, no external power supply or battery installation is required.
- The wireless switch is fixed with strong double-sided adhesive, please choose a suitable location before installing.
- Please install the wireless switch on the wall or the vertical surface of the cabinet within 6 meters of the wireless mobile socket (See Figure Below), Avoid the oily smokey areas.
- In case of standing water, stop use immediately. Use a hair dryer to completely dry before use.
- The wireless switch may be viewed as a toy by children - install it out of the reach of children.
- A stainless-steel countertop will cause signal attenuation and the machine cannot receive signals normally. Therefore, it is recommended that customers who use all-stainless-steel countertops place the switch as close to the receiving device as possible. If it still cannot be effectively controlled, then customers are advised to switch to air switch installation.

7. 垃圾处理器与配管连接 Connection of Waste Disposer and Piping

• 与摩恩 SB021 的连接 Connection with Moen SB021

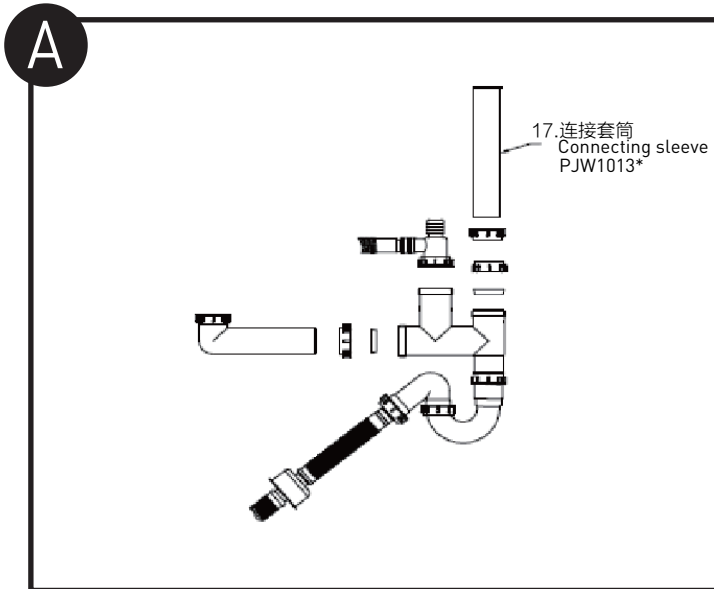

按照示意图重新组装配管（去掉部分多余的零件），将附带的连接套筒（17）组装好。

Reassemble the assembly pipe according to the schematic diagram (remove some redundant parts), and assemble the attached connecting sleeve (17).

• 与摩恩 SB032 的安装 Connection with Moen SB032

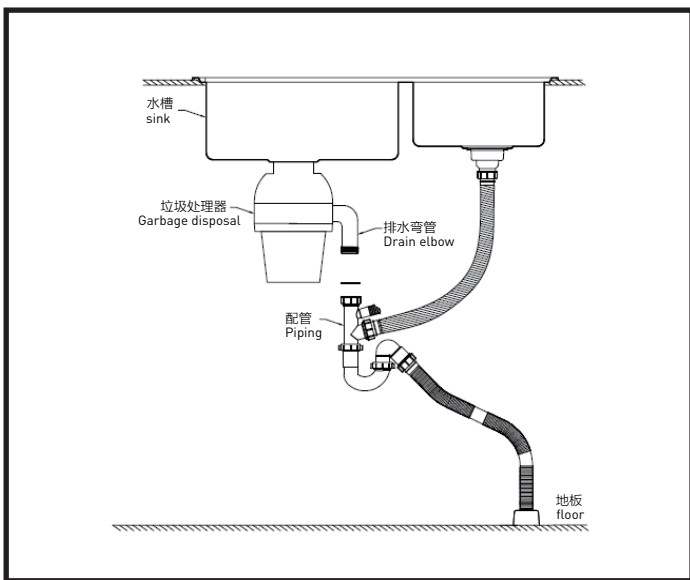

垃圾处理器的出水管可直接连接摩恩落水配管。
The outlet pipe of the waste disposer can be directly connected to the Moen downwater pipe.

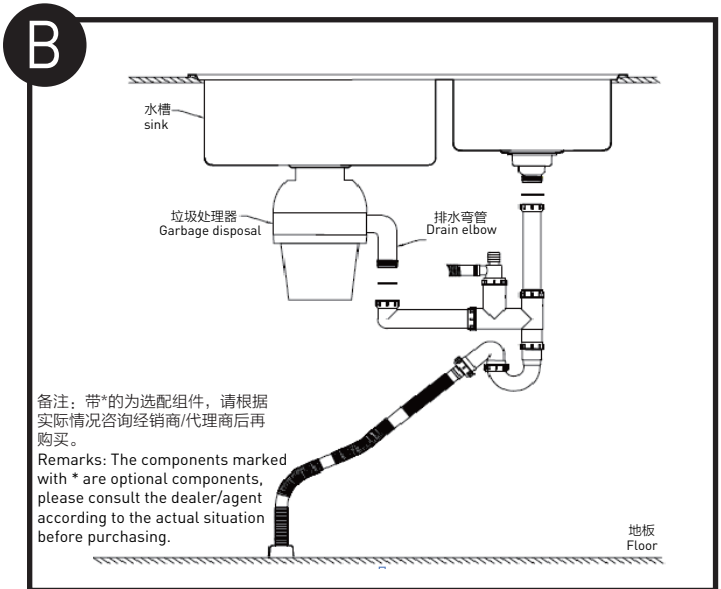

垃圾处理器的出水管直接连接重新组装。
The outlet pipe of the waste disposer is directly connected and reassembled.

• 与摩恩双槽管的安装 Connection with Moen Double Slot Pipe

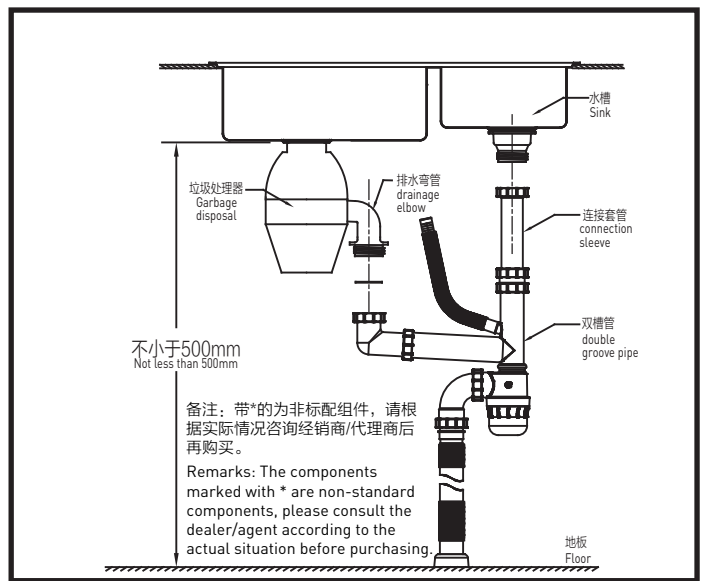

按照示意图，用连接套将摩恩双槽管连接到垃圾处理器。
According to the schematic diagram, use the connecting sleeve to connect the Moen double-slot pipe to the waste disposer.

使用注意事项

- 本产品使用防阻塞旋转刀片，在启动时可能会产生“咔咔”的声音，这属于正常现象。取出水槽塞子，打开冷水龙头，使水流适中。
- 将电开关拨到“开”的位置，此时您的处理器已在高速旋转，并可以使用了。
- 倒入食物垃圾。为保持废弃食物处理器高效工作，请将大块的骨头、瓜皮、玉米棒等切碎成小块投入处理器，但这些东西可能会使处理器的工作时间延长。
- 当处理器粉碎食物的时候。可能速度会慢下来，这属于正常现象，因为处理器正在自行调整转矩（粉碎功率）。
- 应使水和处理器再工作 25 秒左右。这样可以保证所有的污物被水冲洗干净。
- 在处理器工作的时候，不建议您使用热水。冷水可以保证食物垃圾和油脂处于固态并被冲洗干净。
- 家庭厨房用食物处理器仅用来间断使用，不能作为连续使用的商用型处理器。为了排水系统畅通，请您在使用洗碗机之前确认处理器内无食物垃圾。
- 在不使用处理器的时候，请将水槽塞盖好，以防止厨具或其他物品掉入处理器。
- 正确的操作可以延长处理器的使用寿命。它可以处理所有常规的食物垃圾，但不能粉碎或处理罐头瓶子、玻璃、瓶盖、陶瓷类、金属类、皮革、布、橡胶、线、牡蛎壳、羽毛等物。这些垃圾应丢入垃圾箱，不要使用废弃食物处理器处理。
- 饭前、饭后使用处理器！备餐时打开处理器和冷水，将池内的蔬菜叶等清理干净。饭后，可直接将食物垃圾投入处理器。
- 为保证处理器的工作效率，请将大块的食物垃圾切碎后再处理，如骨头、芒果核、玉米棒心。这些垃圾的处理可能会延长处理器的工作时间。或者将这些垃圾丢到垃圾箱或垃圾袋里。
- 水流量最好不低于 4 升/每分钟。

Precautions for Use

- This product uses an anti-clogging rotating blade, which may produce a "click" sound when it is started. This is a normal.
- Take out the sink plug and turn on the cold water tap to make the water flow moderately.
- Turn the electric switch to the "on" position, At this time the processor will spin at a high speed and is ready to use.
- Pour in food waste. To keep the waste food disposer working efficiently, please chop up large pieces of bone, melon skins, corn cobs, etc. into small pieces before placing in disposer. These items may prolong the working time of the disposer and the speed may slow down. This is normal because the processor is adjusting the torque (smashing power) automatically.
- The water and processor should be allowed to work for another 25 seconds after grinding is complete. This will ensure that all dirt is washed away by water.
- When the processor is working, it is not recommended that you use hot water. Cold water keeps food waste and grease in a solid state and is washed away.
- Food processors for home kitchens are only used for intermittent use and cannot be used as commercial processors for continuous use.
- To keep the drainage system unobstructed, please make sure that there is no food waste in the processor before using the dishwasher.
- When the processor is not in use, please cover the sink to prevent kitchen utensils or other items from falling into the processor.
- Correct operation can prolong the service life of the processor. It can dispose of all conventional food waste, but cannot crush or dispose of cans, bottles, glass, bottle caps, ceramics, metals, leather, cloth, rubber, thread, oyster shells, feathers, etc. This rubbish should be thrown into the trash can.
- Use the processor before and after meals! Turn on the processor and cold water when preparing meals and clean the vegetable leaves in the pool. After the meal, the food waste can be directly put into the disposer.
- To ensure the efficiency of the processor, please chop up large pieces of food waste before disposing, such as bones, mango pits, and corn cob hearts. Disposal of this garbage may extend the working time of the processor. Or throw the trash into the trash can or trash bag.
- Water flow rate preferably not lower than 4 liters / min.

故障检修

当您遇到如下问题需要修理，更换零配件或打算用工具卸下被卡住的旋转部件之前，应关闭处理器的电源开关或将插头从插座中拔出，我们建议您进行如下检查：

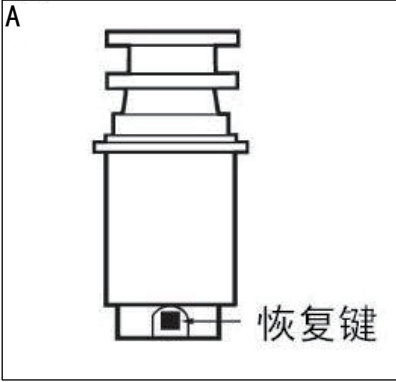
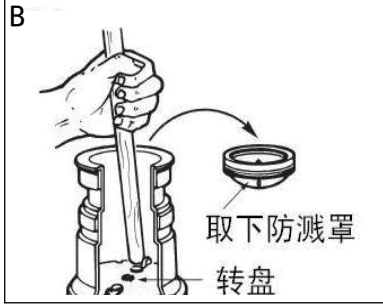
故障现象	故障原因	处理方法
噪音过大	骨头或果核过大时，也有可能勺子等物体掉入处理器。	此时应关闭电源，待处理器完全停止后，取下防溅罩，用长柄工具将物体取出，再盖回防溅罩。
无法启动	热保护器复位按键弹出； 电源开关、保险闸门、电源断合器等故障； 处理器电源线连接部分或内部电气部分的故障。 	关闭电源，取出防溅罩，用长柄工具拨动转盘，查看是否转动自如。如果转盘转动自如，盖回防溅罩，再查看“热保护器复位按钮”是否弹出，“热保护器复位按钮”是红色的，在电源线引出端的正背面，接近底座位置，使用类似于筷子粗细的木棒可以直接触及到（见示意图A），如弹出将其按下即可复位，然后再接通电源启动（可能存在复位按钮无法即时按下的现象，这是电机过热，保护器还处于保护状态，正常情况下间隔30分钟以后，可以按下复位按钮）。如果“热保护器复位按钮”未弹出，请检查处理器的连接电源线，或电源开关、保险闸门、电源断合器等。如果电源线连接和电器部分都完好，有可能是处理器内部的问题，需要与分销商联系修理或更换。
转盘不能自如转动	处理器的转盘与粉碎腔内有异物存在。 	此时应关闭电源，待处理器完全停止后，取下防溅罩，用长柄工具拨动转取出异物（见示意图B），再盖回防溅罩。如果没有异物，就可能是机器内部的问题，需要与分销商联系修理或更换。
渗漏	水槽凸缘安装不合适； 支撑环安装不合适； 弹性垫圈失效； 如果机器从排水弯管处渗漏，那可能是此处螺丝未拧紧。	渗漏存在漏电安全隐患，请关闭电源，需要与分销商联系修理或更换。
漏电	需专业人员现场分析检查！	请关闭电源，联系分销商处理！

Troubleshooting

Turn off the processor's power switch or pull the power plug before performing any repairs, replacement of parts, or using any tools on the unit. recommend that the following checks are performed:

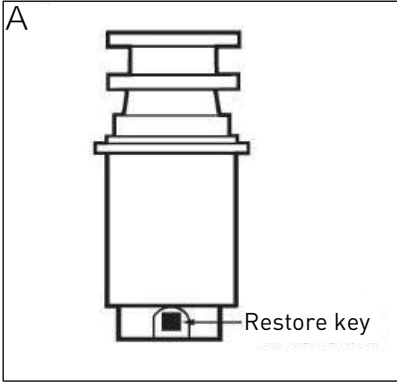
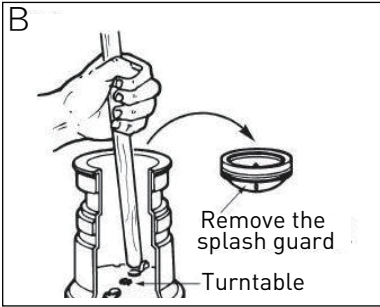
Symptoms	Rootcause	Solution
Excessive noise	When the bones or pits are too large, objects such as spoons may also fall into the processor.	At this time, the power should be turned off, and after the processor has completely stopped, remove the splash guard. Use a long-handled tool to take out the object then replacel the splash guard.
Unable to start	<p>The reset button of the thermal protector pops up; power switch, safety gate, power off :failure of combiner .; failure of processor power cord connection part or internal electrical part.</p> 	<p>Turn off the power and take out the splash guard. Turn the turntable with a long-handled tool to check whether it can rotate freely. If the turntable rotates freely, replace the splash cover, and then check whether the "thermal protector reset button" pops up.</p> <p>The "thermal protector rest button" is located on the back by the lead-out end of the power cord, close to the base position. Use a wooden stick (similar to chopsticks) to push the reset button (see Figure A). If it pops up, press it to reset, and then turn on the power to start. Note, there may be times when the reset button cannot be pressed immediately. This is due to the motor overheating and the protector is still in protection. Normally, the interval is 30 minutes. Wait a few minutes and try again.</p> <p>If the "thermal protector reset button" does not pop up, check the power connection cord, the power switch, safety gate, and power disconnecter. If the power cord connection and electrical parts are intact, there may be a problem inside the processor, and you need to contact the distributor for repair or replacement.</p>
The turntable can't rotate freely	<p>There are foreign objects in the turntable and crushing cavity of the processor.</p> 	<p>Turn off the power to the unit. After the processor has completely stopped, remove the splash cover, and use a long-handled tool to turn and remove the foreign objects (see Figure 7B). Replace the splash cover. If there is no foreign matter, it may be a problem inside the machine, and you need to contact the distributor for repair or replacement.</p>
Seepage	<p>Improper installation of the sink flange; the support ring is not installed properly; the elastic washer failed.</p> <p>If the machine leaks from the drain elbow, it may be that the screws are not tightened.</p>	<p>There is a potential safety hazard for leakage, please turn off the power supply and contact the distributor for repair or replacement.</p>
Leakage	Professional on-site analysis and inspection are required!	Please turn off the power and contact the distributor!

日常清洁和维护

- 处理器电机已有终身润滑剂，请勿另行添加润滑剂！机器自身也可自行清洗。
- 处理器都配有可拆卸或防溅罩。其清洗及更换十分容易。您只须从水池上方将其取出即可，清洗后再放回原处。
- 防溅罩在长期使用中容易损件，如需更换请与销售代理商联系。
- 用户在使用过程中，如有发现在装盘上有黑色胶状物时，请不要担心。那是余量的转盘螺纹密封胶由于电机的高速旋转而产生的飞溅，不影响产品的使用。
- 严禁将碱液和化学制剂倒入处理器，以免内部的金属件受到腐蚀。

Daily Cleaning and Maintenance

- The processor motor has a lifetime lubricant, please do not add other lubricant! The machine can also be cleaned by itself.
- The processors are equipped with removable splash guards. It is easy to clean and replace by removing it from the top of the sink, cleaning it and putting it back in place.
- The splash guard may wear down with long-term use. If you need to replace it, please contact the sales agent.
- During use, if you find a black gel on the tray, this is normal. This is the splash of the remaining turntable thread sealant due to the high-speed rotation of the motor. This does not affect the use of the product.
- It is strictly forbidden to pour lye and chemical agents into the internal metal parts.

产品售后保修条款

摩恩产品是在高质量标准及生产工艺下制造的，摩恩承诺为消费者购买的洁具产品提供有期限免费保修及终身维修服务。

食物垃圾处理器的免费保修期为5年，其它附件的保修期均为3年有限。均自消费者购买日（以摩恩产品分销商开具的发票或收据上载明日期为准）起计。

免费保修范围为产品及产品配件（如淋浴杆、软管、花洒、落水、把手、装饰盖、提拉杆、混水器等）由于材质及工艺原因而造成的故障或损坏。免费保修期内，我们将无偿为您提供维修服务及更换发生故障的产品或产品配件。摩恩的售后服务责任仅限于对故障产品的修理，而不延及您因产品故障而发生的其他损失，法律另有规定的除外。

您需了解：产品外观碰伤、刻划痕迹，以及滥用及不正当保养所导致的故障或损坏，均不属于免费保修范围。即使在免费保修期内，属下列（1）-（5）情况之一的，需酌情收取修理费用：

1. 不能出示相符的保修卡和有效购买凭证情况的，
2. 未按使用说明告知的使用方法和注意事项造成的故障，
3. 自行拆卸、维修、改装所造成的故障和损坏，
4. 由于不可抗力等外部原因引起的故障和损坏，
5. 由于运输、搬卸、挤压等造成的损坏。

对于保修期外或不在保修范围内的产品，如需维修，摩恩将酌情收取上门费、人工费及材料费。

本保修条款仅对原始消费者和酒店行业的购买者有效，并不适用于本产品工业、商业、贸易和非酒店行业的使用。

如对本保修条款内容有任何疑问，请拨打400 630 8866 咨询热线，或向当地分销商咨询。

MOEN LIMITED WARRANTY

We offer limited warranty and lifetime maintenance for Moen products, which are all manufactured with high standards of workmanship.

The period of warranty shall start from the date of purchase of the product (according to the invoice or receipt issued by Moen distributors) and shall cover a period of the following: the warranty period for waste disposer is 5 years, and the warranty period for other accessories is 3 years.

This warranty is your coverage against material and workmanship malfunction or defects in Moen products or components. During the warranty period, we offer free maintenance and changing of malfunctioned products or product components. Moen's after sales service liability is limited to the maintenance of faulty items and does not cover your other losses caused by product malfunction, except for otherwise stipulated by law.

Cosmetic damages (scratches, dents, etc.) and malfunction or defects caused by abuse or improper maintenance is not covered by this warranty. Although the warranty period remains valid, in case of the following conditions (1) - (5), the maintenance cost (material cost and labor cost) shall still be charged as the case may be:

1. Corresponding warranty card and valid invoice cannot be presented;
2. Faults were caused by the incompliance with the instructions and precautions provided in the user's manual;
3. Damages and faults were caused by self-actuated dismantling, repair and refit;
4. Faults and damages were caused by external factors such as force majeure;
5. Damages were caused by transportation, unloading and extrusion, etc.

This warranty is valid for the original consumers only (including hotel use), and excludes industrial and commercial use of the product (except for hotel use). This card is only responsible for product maintenance rather than any other liabilities.

In the event that the product requires maintenance but exceeds the warranty period, or that the product is not covered by this warranty, labor cost and material cost shall be charged as the case may be.

Please call 400-630-8866 or contact local dealer for any question.

MOEN® 摩恩

合格证 Compliance Certification

产品名称 垃圾处理器
Product Name Waste Disposer

检验员 _____
Inspector _____

生产日期 _____
Date of Production _____

摩恩（上海）厨卫有限公司
中国（上海）自由贸易试验区富特北路399号
邮编：200131

MOEN (SHANG HAI) KITCHEN & BATH PRODUCTS CO., LTD
No. 399 Fute North RD, China (Shanghai) Pilot Free Trade Zone,
Shanghai 200131 P.R. China